



Electronics
WORKBENCH



multiSIM 7

Simulation & Capture



Getting Started & Tutorial Guide

multiSIM™ and Electronics Workbench™ copyright © 1989, 1992-2003
Interactive Image Technologies Ltd. All rights reserved.

All other brand or product names are trademarks or registered trademarks of their respective companies or organizations.

MSM7-E-1786 R.1.

© 2003 Interactive Image Technologies Ltd. All rights reserved. Published May 2003.
Printed in Canada.

Preface

Congratulations on choosing Multisim 7 from Electronics Workbench. We are confident that it will deliver years of increased productivity and superior designs.

Electronics Workbench is the world's leading supplier of circuit design tools. Our products are used by more customers than those of any other EDA vendor, so we are sure you will be pleased with the value delivered by Multisim 7, and by any other Electronics Workbench products you may select.

Documentation Conventions

When Multisim 7 manuals refer to a toolbar button, an image of the button appears in the left column.

The manuals show circuits in black and white, although Multisim 7 is configured to use color by default. (You can change the color scheme.)



When you see the icon in the left column, the functionality described is only available in certain versions of Multisim 7, or to users who have purchased optional modules.

Multisim 7 manuals use the convention **Menu/Item** to indicate menu commands. For example, “**File/Open**” means choose the **Open** command from the **File** menu.

Multisim 7 manuals use the convention of an arrow (➤) to indicate the start of procedural information.

Multisim 7 manuals use the construction CTRL-KEY and ALT-KEY to indicate when you need to hold down the “Ctrl” or “Alt” key on your keyboard and press another key.

The Multisim 7 Documentation Set

Multisim 7 documentation consists of this *Getting Started and Tutorial* manual, a *User Guide*, and on-line help. All Multisim 7 users receive PDF versions of the *Getting Started and Tutorial* manual, the *Component Reference Guide* and the *User Guide*. Depending on your version of Multisim 7, you may also receive a printed version of the manuals.

Getting Started and Tutorial

The *Getting Started and Tutorial* manual introduces you to the Multisim 7 interface. It also offers an introductory tutorial that takes you through the stages of circuit design, simulation, analysis and reporting.

User Guide

The *User Guide* describes Multisim 7 and its many functions in detail. The manual is organized based on the stages of circuit design, and explains all aspects of using Multisim 7, in detail.

On-Line Help

Multisim 7 offers a full help file system to support your use of the product. Choose **Help/Multisim Help** to display the help file that explains the Multisim 7 program in detail, or choose **Help/Multisim Reference** to display the help file that contains reference material (from the appendices) such as details on all the components families provided with Multisim 7. Both are standard Windows help files, offering a table of contents and index.

In addition, you can display context-sensitive help by pressing F1 from any command or window, or by clicking the **Help** button on any dialog box that offers it.

Adobe PDF Files

Both the *Getting Started and Tutorial* manual and the full *User Guide*, including appendices, are provided on the Multisim 7 CD as Adobe PDF files and are accessible from the Multisim 7 program folder on the Windows Start menu. To open PDF files, you will need Adobe's free Acrobat Reader program, available for download at www.adobe.com.

License Agreement

Please read this license carefully before installing and using the software contained in this package. By installing and using the software, you are agreeing to be bound by the terms of this license. If you do not agree to the terms of this license, simply return the unused software within thirty days to the place where you obtained it and your money will be refunded.

1. Copyright. The software in this package is copyright Interactive Image Technologies Ltd.(IIT) the parent company and owner of Electronics Workbench. The software is licensed for use only on the terms set forth herein.

Single User Version. This Agreement permits you to install one copy of the software, which is licensed as a single product. The software is installed on a computer when it is loaded into the hard drive or any other storage device of that computer. You must pay for additional copies if you wish to install the software on more than one computer at the same time or on a network. Certain exceptions to this policy exist in specific circumstances. Please contact Electronics Workbench for details.

Multi-Station Standalone and Non-Floating Network Version. This multi-station license allows you to install this software on the number of stations specified below. Each station shall consist of only one computer with only one user at a time. If your multi-station version is to be used in a non-floating network environment, each computer connected to that network from which this software can be run shall be considered one station. If your multi-station version is to be used in an environment where the software is not accessed using

a network (i.e. standalone configuration), each computer shall be considered one station. For any combination of non-floating and standalone stations, the respective methods of counting (as explained above) shall apply and be totaled. The total number of stations your particular multi-station license is restricted to is _____.

Floating Network Version. This floating network license allows you to install this software on a network. Each station shall consist of only one computer with only one user at a time. The number of users restricted by this license is determined by the total number of concurrent users running the software from the network at the same time. The total number of concurrent users your particular floating network license is restricted to is _____.

2. Limited Warranty. IIT warrants that under normal use for a period of thirty (30) days from the date of delivery that: (a) the media on which the software is furnished will be free from defects in the material and workmanship; and (b) the software will operate substantially as described in the User's Guide (documentation). In order to make a claim under this warranty you must call IIT for authorization to return any defective item during the warranty period. If you return merchandise to IIT, you must insure the defective item being returned because IIT does not assume the risk of loss or damage while in transit.

Upon return of a defective item, IIT shall, upon verification of the defect or error, at IIT's option, either repair or replace the defective copy or refund the amount paid for the license. If IIT elects to provide a refund, upon the date you receive notice of such election, this license shall terminate and you must comply with the provisions set out below.

You must assume full responsibility for the selection of this software to achieve your intended purposes, for the proper installation and use of the software and for verifying the results obtained from use of the software. IIT does not warrant in any way that the functions contained in the software will meet your requirements, that the software is fit for any particular purpose or that the operations of the software will be uninterrupted and error-free.

3. Term. The License granted in this agreement is effective until termination. Your misuse shall automatically terminate this license if you breach any of its terms and conditions. Upon termination, you shall return all media containing the software and all documentation to IIT and destroy any copies of the software or any portions of it which have not been returned to IIT, including copies resident in computer memory.

4. Copies, Modification or Merger. You shall not copy or modify all or any portion of the software or documentation or merge it into another software program. Copies shall include, without limitation, any complete or partial duplications on any media, adaptations, translations, compilations, partial copies within modifications, mergers with other material from whatever source, and updated works. You shall use your best efforts to prevent any unauthorized copying of the software.

You shall not make any change or modification to any of the executable files, nor shall you reverse engineer, de-compile or disassemble the software or any portion of it, or otherwise attempt to determine the underlying source code of the software or permit any such actions.

5. Disclaimer/Limitation of Liability. IIT expressly disclaims all other warranties, whether oral or written, express or implied, including without limitation warranties of merchantability or fitness for a particular purpose. All warranties shall terminate thirty days from date of delivery of the software to you.

Your exclusive remedy and IIT's entire liability arising from or in connection with the software, the software documentation, and/or this license (including without limitation for breach of warranty) shall be, at IIT's option, the repair or replacement of the media on which the software is supplied or refund of license fee.

In no event shall IIT's total liability for any damages, direct or indirect, in connection with the software, the software documentation, and/or this license exceed the license fees paid for your right to use this copy of the software, whether such liability arises from any claim based upon contract, warrants, tort or otherwise. In no event shall IIT or its partners be liable for any loss of profit or any other commercial damage, including but not limited to special, incidental, consequential or other damages, resulting from or in any way connected with the use of this software and including but not limited to any damages resulting from the use of the software for any special or high-risk applications such as those relating to or involving nuclear designs, medical devices and other critical or potentially dangerous applications.

IIT specifically disclaims any other warranties, expressed or implied, including but not limited to the implied warranties of merchantability and fitness for a particular purpose.

Some jurisdictions do not allow the exclusion of implied warranties, so the above exclusion may not apply to you. In that event, any implied warranties are limited in duration to thirty (30) days from the date of delivery of the software. This warranty gives you specific legal rights. You may have other rights, which vary from jurisdiction to jurisdiction.

No action for any breach of warranty shall be commenced more than one year following the expiration of such warranty.

6. General. You acknowledge that you have read this agreement, understand it and agree to be bound by its terms and conditions. You further agree that it is the complete and exclusive statement of the agreement between you and IIT and supersedes any proposal or prior agreement or any other communications between IIT and you relating to the use of the software.

If any provision of this Agreement is unenforceable, all others shall remain in effect. This Agreement shall be governed by the internal laws of the Province of Ontario and Canada, including Canadian copyright laws. The exclusive venue in the event of any suit, proceeding or claim brought by you, and at our option, any suit, proceeding or claim brought by IIT, shall be in the Courts located in Metropolitan Toronto, Ontario. If you have any questions regarding this Agreement, you may contact IIT by writing to us at the address set out below:

INTERACTIVE IMAGE TECHNOLOGIES LTD.

111 Peter Street, Suite 801 Toronto, Ontario M5V 2H1 **Tel:** (416) 977-5550

Fax: (416) 977-1818 **e-mail:** ewb@electronicsworkbench.com

Internet: www.electronicworkbench.com

Table of Contents

1. Introduction

1.1	About this Chapter	1-1
1.2	About this Manual	1-1
1.3	What is Multisim 7?	1-1
1.4	About Installation	1-2
1.5	Installing Multisim 7	1-3
1.6	Installing Feature Codes for Previously Installed Versions of Multisim 7	1-10
1.7	Uninstalling Multisim 7	1-11
1.8	How to Reach Us	1-12
1.9	Introduction to the Multisim 7 Interface.	1-13
1.10	Configuring Multisim 7 Preferences	1-20

2. Building a Circuit

2.1	Introduction	2-1
2.2	Starting Your Circuit File	2-2
2.3	Placing Components in the Circuit Window	2-2
2.4	Changing the Label and Color of Individual Components and Nodes	2-9
2.5	Wiring	2-9
2.6	Using the Spreadsheet View	2-14
2.7	Adding a Title Block to the Circuit.	2-15
2.8	Adding Text to the Circuit	2-16
2.9	Adding Graphic Annotation to the Circuit	2-16
2.10	Conclusion	2-17

3. Editing a Component

- 3.1 Introduction to Component Editing3-1
- 3.2 Editing a Component3-2
- 3.3 Editing a Symbol Using In-Place Edit3-3
- 3.4 Conclusion3-3

4. Adding Instruments to Your Circuit

- 4.1 Introduction4-1
- 4.2 Adding and Connecting Instruments4-2
- 4.3 Configuring Instrument Settings4-4
- 4.4 Conclusion4-5

5. Simulating Your Circuit

- 5.1 Simulating your Circuit.5-1
- 5.2 Viewing Simulation Results5-1
- 5.3 Using the Dynamic Measurement Probe5-3
- 5.4 Conclusion5-3

6. Performing Analyses on Your Circuit

- 6.1 The Analyses6-1
- 6.2 About Transient Analysis6-2
- 6.3 Running the Analysis6-2
- 6.4 Conclusion6-5

7. Generating a Report

7.1	Introduction	7-1
7.2	Creating and Printing a BOM	7-1
7.3	Conclusion	7-2



Chapter 1

Introduction

1.1 About this Chapter

This chapter introduces you to this manual and to Multisim 7 itself. It also explains how to install the full product and Feature Codes for optional modules.

1.2 About this Manual

This manual is written for all Multisim 7 users. It provides an overview of some of the main Multisim 7 functions, using a tutorial approach where you are led through the steps of building, simulating, analyzing and reporting on a basic circuit. The majority of the functions described in this manual are available to all Multisim 7 users, regardless of their edition of the product. Where the functionality described is available only in some editions of Multisim 7, this is indicated by the presence of this symbol in the margin.



This manual assumes that you are familiar with Windows applications and know how, for example, to choose a menu from a command, use the mouse to select an item, and enable/disable an option. If you are new to Windows, see your Windows documentation for help.

1.3 What is Multisim 7?

Multisim 7 is a complete system design tool that offers a very large component database, schematic entry, full analog/digital SPICE simulation, co-simulation with optional HDL product, RF capabilities, Postprocessing features and seamless transfer to PCB layout packages such as Ultiboard from Electronics Workbench. It offers a single, easy-to-use graphical interface for all your design needs.

Multisim 7 provides all the advanced functionality you need to take designs from specification to production. And because the program tightly integrates schematic capture, simulation, and programmable logic, you can design with confidence, knowing that you are

free from the integration issues that often arise when exchanging data between applications from different vendors.

1.4 About Installation

1.4.1 Installation Requirements

To successfully install Multisim 7, you may need up to 50 MB of hard disk space, depending on which edition you have purchased. You also need, as a minimum, the following system requirements:

- Windows 98/NT 4/2000/XP
- Pentium II+
- 64 MB RAM (128MB recommended)
- CD-ROM drive
- 800 x 600 minimum screen resolution

1.4.2 Installation Types

Multisim 7 has two types of installation: Single User Version and Site License Version.

Single User Version. If you are installing Multisim 7 on a single computer that is not connected to another computer, you are installing a Single User Version. For details on the installation process see “1.5.1.1 Installing the Single User Version” on page 1-3.

Site License Version. If you are installing Multisim 7 on a computer that is intended to be used in a network, or on several standalone computers, you are installing a Site License Version. Site License Versions are available in three types: Multi-Station Standalone Installation, Network Installation, and Combination Multi-Station and Network Installation.

Multi-Station Standalone Installation. This installation is used if you are installing Multisim 7 on more than one computer where the computers are not connected to one another through a network. You can install Multisim 7 on each of the computers separately using one copy of the program. For specific details on the number of stations allowed to be installed, please see the Site License Version section of the License Agreement at the front of this book. For details on this installation process see “1.5.2.1 Multi-Station Standalone Installation” on page 1-5.

Network Installation. This installation is used if you are installing Multisim 7 on a network and the number of concurrent users, not the number of computers connected to the network, is being counted. This is called a floating license. For specific details on the

number of stations allowed to be installed, please see the Site License Version section of the License Agreement at the front of this book. For details on this installation process see “1.5.2.2 Network Installation” on page 1-7.

Combination Multi-Station Standalone and Network Installation. This installation is used if you are installing Multisim 7 on a number of standalone machines *and* on a network environment. You can install Multisim 7 on each of the computers separately using one copy of the program. With the same copy, you can then install the software on the network. For special details on the number of stations allowed to be installed, please see the Site License Version section of the License Agreement at the front of this book. For details on this installation process see “1.5.2.3 Combination Multi-Station Standalone and Network Installation” on page 1-10.

1.5 Installing Multisim 7

1.5.1 Single User Version

1.5.1.1 Installing the Single User Version

The CD-ROM you received in your Multisim 7 package is self-starting. Follow the directions below and on the screen during the installation process.

➤ To install Multisim 7:

1. Copy your serial number (2 letters and 18 numbers) and Feature Code(s) in the spaces below. You will find these numbers on the front of the CD-ROM package.

Serial number _____

Feature code _____

Note The Feature Code is *not* the same as your serial number. Only users who have purchased additional features with Multisim 7 receive a Feature Code.

2. Exit *all* Windows applications prior to continuing.
3. Insert the Multisim 7 CD into your CD-ROM drive. When the “Welcome” screen appears, read it. Click **Next** to continue.
4. Read the License Agreement, which can also be found in the front of this manual. To accept the terms of the agreement, and to continue to the next screen, click **Yes**. If you do not accept the terms of the agreement, click **No** and the Multisim 7 installation will be terminated.
5. Enter your name, company and serial number (recorded above). Click **Next** to continue.

6. If you did not receive a Feature Code with Multisim 7, this step is not required. Click **Next** to continue.

If you purchased optional modules with Multisim 7, you will also have received a Feature Code for each module. Enter the first Feature Code and click **Next**. A new blank field appears. Continue entering the provided Feature Codes and clicking **Next** until you have entered all the Feature Codes you need. Leave the last field empty and click **Next**.

7. Select the location in which you want to install Multisim 7. Choose the default folder or click **Browse** to select a different location or to enter your own folder name. Click **Next** to continue.
8. Users upgrading from Multisim 2001 will be prompted to import and convert earlier versions of the Corporate and User Databases. Choose **Yes** or **No**. If you choose not to proceed with the conversion at this time you may convert later from within Multisim.
9. Setup will create the program folder. Click **Next** to continue.

Multisim 7 will finish being installed. If for any reason you wish to stop the installation, click **Cancel** and the installation of Multisim 7 will be terminated.
10. If upgrade users elected to import and convert their Corporate and User Databases and duplicate component names are detected, the **Duplicate Component Name** dialog box will appear. Select the desired option:
 - **Auto-Rename** — Import and automatically rename the duplicate components.
 - **Overwrite** — Replace the Multisim 7 components with Multisim 2001 components.
 - **Ignore** — Do not import Multisim 2001 components with duplicate names.
11. If necessary, you will be prompted to re-boot your computer after installation.

1.5.1.2 Getting the Release Code for the Single User Version

When you run Multisim 7, the splash screen will prompt you for a Release Code. The screen indicates that a grace period of 15 days is provided starting on the day of installation. Each day the grace period will decrease by one day. When the grace period reaches the 16th day, Multisim 7 will not run until the Release Code is provided. Electronics Workbench strongly recommends that you obtain your Release Code as soon as possible after you have installed Multisim 7.

To obtain your Release Code, you must have your serial number and signature code available (these are both displayed on the splash screen). Contact Electronics Workbench via our web site at www.electronicsworkbench.com and select Product Registration, or call our Customer Service number at 1-800-263-5552. Customers outside North America can also contact their local distributor.

- To enter the Release Code:
 1. At the splash screen, click **Enter Release Code**. This enables the text box to be active.
 2. Enter the Release Code number and click **Accept** to continue.

1.5.2 Site License Version

Site License Versions are available in three types: Multi-Station Standalone Installation, Network Installation, and Combination Multi-Station and Network Installation.

1.5.2.1 Multi-Station Standalone Installation

Installing the Multi-Station Standalone Installation

The CD-ROM you received in your Multisim 7 package is self-starting. Follow the directions below and on the screen during the installation process. Your license allows you to install the software on the number of computers indicated in the Site License Version section of the License Agreement at the front of this book.

Copy your serial number (2 letters and 18 numbers) in the space below. You will find this number on the front of the CD-ROM package.

Serial number _____

- To install Multisim 7, follow these instructions for each computer on which you are licensed to install the software:
 1. Exit *all* Windows applications.
 2. Insert the Multisim 7 CD into your CD-ROM drive. When the “Welcome” screen appears, read it. Click **Next** to continue.
 3. Read the License Agreement, which can also be found in the front of this manual. To accept the terms of the agreement, and to continue to the next screen, click **Yes**. If you do not accept the terms of the agreement, click **No** and the Multisim 7 installation will be terminated.
 4. Enter your name, company and serial number (recorded above). Click **Next** to continue.
 5. If you did not receive any Feature Codes, this step is not required. Click **Next** to continue and go to step 7.

Feature Codes are used to install add-on modules and to release network seats for Network Installations. Locate the Features Code(s), on the front of the CD-ROM package, that are for add-on modules.

Copy your Feature Code for add-on modules in the space below.

Feature code for add-on modules: _____

Note Do not use the Feature Code for Network Seats in your Multi-Station Standalone Installation. This Feature Code is intended for use in installing the Network portion of a Combination Multi-Station Standalone and Network Installation.

6. In the installation window, enter the first Feature Code for add-on modules and click **Next**. A new blank field appears. Continue entering the provided Feature Codes for add-one modules and clicking **Next** until you have entered all the Feature Codes you need for add-on modules. Leave the last field empty and click **Next**.
7. Select the Destination location in which you want to install Multisim 7. Choose the default folder or click **Browse** to select a different location or to enter your own folder name. Click **Next** to continue.
8. Users upgrading from Multisim 2001 will be prompted to import and convert earlier versions of the Corporate and User Database. Choose **Yes** or **No**. If you choose not to proceed with the conversion at this time you may convert later from within Multisim.
9. Setup will create the program folder. Click **Next** to continue.

Multisim 7 will now finish being installed. If for any reason you wish to stop the installation, click **Cancel** and the installation of Multisim 7 will be terminated.

10. If upgrade users elected to import and convert their Corporate and User Databases and duplicate component names are detected, the **Duplicate Component Name** dialog box will appear. Select the desired option:
 - **Auto-Rename** — Import and automatically rename the duplicate components.
 - **Overwrite** — Replace the Multisim 7 components with Multisim 2001 components.
 - **Ignore** — Do not import Multisim 2001 components with duplicate names.
11. If necessary, you will be prompted to re-boot your computer after installation.
12. Repeat the installation for each workstation.

The Site License Version section of the License Agreement at the front of this identifies the total number of stations to which your particular multi-station license is restricted. This is controlled by the software.

Getting the Release Code for the Multi-Station Standalone Installation

You will notice when you run Multisim 7 that the splash screen will prompt you for a Release Code. The screen indicates that a grace period of 15 days is provided starting on the day of installation. Each day the grace period will decrease by one day. When the grace period reaches the 16th day, Multisim 7 will not run until the Release Code is provided. Electronics Workbench strongly recommends that you obtain your Release Code as soon as possible after you have installed Multisim 7.

Note The Release Code will be the same for each workstation.

To obtain your Release Code, you must have your serial number and signature code available (these are displayed on the splash screen). Contact Electronics Workbench via our web site at www.electronicsworkbench.com and select Product Registration, or call our Customer Service number at 1-800-263-5552. Customers outside North America can also contact their local distributor.

- To enter the Release Code, on each computer for which you installed Multisim 7:
 1. At the splash screen, click **Enter Release Code**. This enables the text box to be active.
 2. Enter the Release Code number and click **Accept** to continue.
 3. Perform steps 1 and 2 for each workstation.

1.5.2.2 Network Installation

Installing the Network Installation

The CD-ROM you received in your Multisim 7 package is self-starting. Follow the directions below and on the computer screen during the installation process.

1. Copy your serial number (2 letters and 18 numbers) and Feature Code(s) in the spaces provided. These numbers are located on the CD-ROM package.

Serial number _____

Feature code for Network Seats _____

Feature code(s) for add-on products _____

Note A Feature Code is *not* the same as your serial number. The network installation includes a Feature Code for unlocking and monitoring the number of network seats your license includes. If you have purchased add-on products with Multisim 7, you will also receive Feature Code(s) for each of the add-on products.

- To install Multisim 7:
 1. Logon with administrator privileges.
 2. Exit all Windows applications prior to continuing.
 3. Insert the Multisim 7 CD into your CD-ROM drive. When the “Welcome” screen appears, read it. Click **Next** to continue.
 4. Read the License Agreement. To accept the terms of the agreement, and to continue on to the next screen click **Yes**. If you do not accept the terms of the agreement, click **No** and the Multisim 7 installation will be terminated.
 5. Enter your name, company and serial number. Click **Next** to continue.
 6. Enter the first Feature Code (you can enter multiple Feature Codes in any order you like). Click **Next**, to continue. A new blank field appears. Continue entering the provided

Feature Codes and clicking **Next** until you have entered all the Feature Codes you received. Leave the last field empty and click **Next**.

7. Select the network drive/location in which you want to install Multisim 7. Click the **Browse** button to select a different location or enter your own folder name. Click **Next** to continue.

Note You *must* install Multisim 7 in a location on the network drive that is accessible to all workstations running Multisim 7.

8. Users upgrading from Multisim 2001 will be prompted to import and convert earlier versions of the Corporate and User Database. Choose **Yes** or **No**. If you choose not to proceed with the conversion at this time you may convert later from within Multisim.
9. The Setup routine will create the program folder. Click **Next** to continue.

If for any reason you wish to stop the installation, click **Cancel** and the installation of Multisim 7 will be terminated.

10. If upgrade users elected to import and convert their Corporate and User Databases and duplicate component names are detected, the **Duplicate Component Name** dialog box will appear. Select the desired option:

- **Auto-Rename** — Import and automatically rename the duplicate components.
- **Overwrite** — Replace the Multisim 7 components with Multisim 2001 components.
- **Ignore** — Do not import Multisim 2001 components with duplicate names.

11. If necessary, you will be prompted to re-boot your computer after installation.

➤ To configure Multisim 7 on each workstation:

1. Logon with administrator privileges.
2. Using Windows Explorer, navigate to the Multisim 7 folder on the network drive.
3. Double-click on the Multisim executable file, `Multisim.exe`.
4. The setup routine will now configure the workstation.
5. If necessary, you will be prompted to re-boot your computer after installation.

Restricting Write Privileges

Access to the Multisim 7 directories should be restricted by placing permissions on various directories. Follow the instructions below to place the appropriate permissions.

Windows NT Client/Server Install

In the main installation directory (N:\Multisim 7, where N: is the network drive where Multisim 7 is installed, and Multisim 7 is the name of the folder specified at installation), share the directory with share permissions for Everyone set to “Full Control”.

Security on the Multisim 7 directory should be:

Administrator	Full Control
User	(R)ead E(X)ecute (W)rite

Set up the directory attributes for subdirectories as follows:

Directory	Attributes - User
Library	(R)ead (W)rite E(X)ecute
Lock	(R)ead (W)rite E(X)ecute
Samples	(R)ead E(X)ecute
Ulticap	(R)ead (W)rite E(X)ecute
Ulticap\Sch	(R)ead (W)rite E(X)ecute

All directories not listed above should have (R)ead E(X)ecute permissions.

Novell Network Client/Server Install

For the main installation directory (N:\Multisim 7, where N: is the network drive where Multisim 7 is installed, and Multisim 7 is the name of the folder specified at installation), map a network drive to the directory. Set up security permissions for this directory as follows:

Administrator	(S)upervisor
User	Special directory access (R)ead (F)ile Scan (C)reate (W)rite

Set up the directory attributes for subdirectories as follows:

Directory	Attributes - User
Library	(R)ead (W)rite (C)reate (F)ile Scan
Lock	(R)ead (W)rite (C)reate (F)ile Scan
Samples	(R)ead (F)ile Scan
Ulticap	(R)ead (W)rite (C)reate (F)ile Scan
Ulticap\Sch	(R)ead (W)rite (C)reate (F)ile Scan

All directories not listed above should have (R)ead (F)ile Scan permissions.

- Running Multisim 7 from any station for the first time:
 1. The first time you startup Multisim 7, you will be asked for a Release Code. Follow the instructions in “1.5.1.2 Getting the Release Code for the Single User Version” on page 1-4, to obtain the applicable Release Code for your system. Only one Release Code is required to operate the Network Installation of Multisim 7.
 2. Electronics Workbench recommends that you obtain the Release Code as soon as possible.

1.5.2.3 Combination Multi-Station Standalone and Network Installation

Follow the instructions in “1.5.2.1 Multi-Station Standalone Installation” on page 1-5 and “1.5.2.2 Network Installation” on page 1-7 as necessary. The total number of users and/or stations is restricted to the total number of users listed in the Site License Version section of the License Agreement at the front of this book.

Note Only one serial number and release code is required for this type of installation.

1.6 Installing Feature Codes for Previously Installed Versions of Multisim 7

If you already have Multisim 7 installed because you purchased it earlier, and have now received Feature Code(s) for optional features which you purchased subsequently, you will need to re-run the initial installation. This lets you enter your Feature Codes into Multisim 7, thereby unlocking the feature. When installing Feature Codes, you do not have to uninstall Multisim 7.

- To install a Feature Code with a previous installation of Multisim 7:
 1. Re-run the Multisim 7 installation program, as described in the previous sections.
 2. When you are prompted, enter the Feature Code in the blank field, and click **Next**. A new blank field appears.
 3. If you have purchased more than one feature, enter the next Feature Code, and click **Next**.
 4. Continue to entering Feature Codes and clicking **Next** until you have entered all the Feature Codes you need.
 5. When you are finished entering Feature Codes, leave the last field empty and click **Next**.

1.7 Uninstalling Multisim 7

1.7.1 Uninstalling Single User Version

1. Ensure you have recorded the serial number and any Feature Codes in “1.5.1.1 Installing the Single User Version” on page 1-3.
2. Click the Windows **Start** button.
3. Click **Settings** and **Control Panel**.
4. Click **Add/Remove Programs**. The Add/Remove Programs Properties screen appears.
5. From the **Install/Uninstall** list, select **Multisim 7** and select **Add/Remove**. Multisim 7 will be removed from your computer.

1.7.2 Uninstalling Site Version

1.7.2.1 Uninstalling Standalone Multi-Station Installation

At each standalone workstation, perform the following procedure:

1. Ensure you have recorded the serial number and any Feature Codes in “1.5.2.1 Multi-Station Standalone Installation” on page 1-5.
2. Click the Windows **Start** button.
3. Click **Settings** and **Control Panel**.
4. Click **Add/Remove Programs**. The Add/Remove Programs Properties screen appears.
5. From the **Install/Uninstall** list, select **Multisim 7** and select **Add/Remove**. Multisim 7 will be removed from the standalone workstation.

1.7.2.2 Uninstalling Network Installation

Only the workstation that was used to install Multisim 7 to the network directory (host computer) can be used to remove it. Performing the steps below on other workstations (client computer) will only remove the Multisim 7 folder and increment the Feature Code monitoring the number of stations.

- To uninstall Multisim 7 from the network directory or the Multisim 7 folder:
 1. Ensure you have the serial number and any Feature Codes written down prior to uninstalling Multisim 7. A space has been provided in 1.4.3 to write the numbers.

2. Click the Windows **Start** button.
3. Click **Settings** and **Control Panel**.
4. Click **Add/Remove Programs**. The Add/Remove Programs Properties screen appears.
5. From the **Install/Uninstall** list, select **Multisim 7** and select **Add/Remove**. If the workstation is the host computer, Multisim 7 is removed from the network directory. If the workstation is only a client computer, the Multisim 7 folder is removed.

1.7.2.3 Uninstalling Combination Standalone Multi-Station and Network Installation

Follow the instructions in “1.7.2.1 Uninstalling Standalone Multi-Station Installation” on page 1-11 and “1.7.2.2 Uninstalling Network Installation” on page 1-11, as necessary.

1.8 How to Reach Us

Electronics Workbench provides you with multiple ways of contacting us. If you have questions, we suggest visiting our Web site at www.electronicworkbench.com to review our frequently asked questions (FAQ) list. Alternatively you can contact us by:

- If you have Internet access, send an email message to support@electronicworkbench.com.
- Fax information to our Technical Support department at (416) 977-1818.
- Call us at (416) 977-5550 and ask for sales or technical support.
- Visit our web page at www.electronicworkbench.com.

1.9 Introduction to the Multisim 7 Interface

1.9.1 Basic Elements

Multisim's user interface consists of the following basic elements:

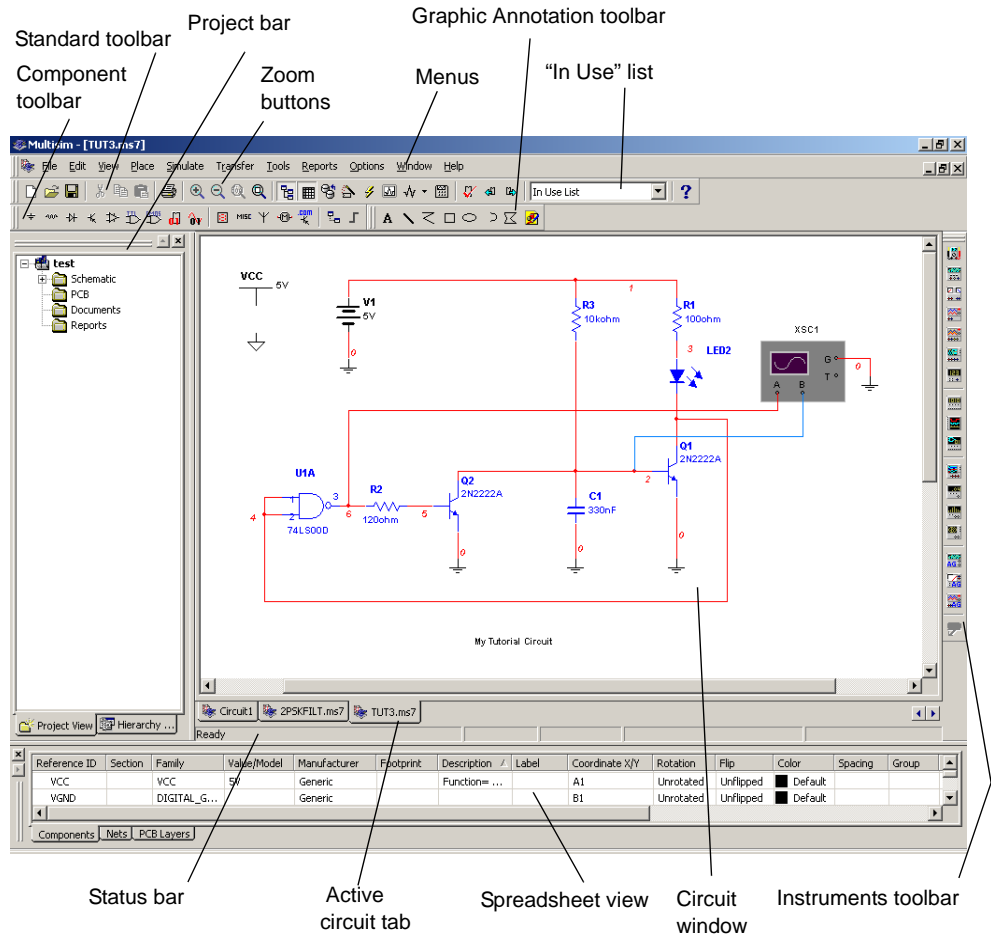

Menus are where you find commands for all functions.

The **Standard Toolbar** contains buttons for commonly-performed functions. Included in this toolbar are the standard Windows-type buttons and the key buttons used to control Product Name.

The **Instruments Toolbar** contains buttons for each instrument.

The **Component Toolbar** contains buttons that let you select components from the Multisim libraries for placement in your schematic. This toolbar includes a link to **EDAparts.com**, which launches your web browser and directs you to the Electronics Workbench EDAparts.com website. You can then navigate the site to download parts.

The **Circuit Window** (or workspace) is where you build your circuit designs.

The **Status Bar** displays useful information about the current operation and a description of the item the cursor is currently pointing to.

The **Project Bar** lets you navigate through the different types of files in a project (schematics, PCBs, reports) or to view a schematic hierarchy.



The **Spreadsheet View** allows fast advanced viewing and editing of parameters including component details such as footprints, RefDes, attributes and design constraints. Users can change parameters for some or all components in one step and perform a number of other functions.

















1.9.2 Multisim 7 Toolbars





1.9.2.1 Standard Toolbar

The **Standard** toolbar contains buttons for commonly performed functions. As well as common functions such Open a New File, Save a File, Print and Zoom there is access to advanced functions.

The buttons in the **Standard** toolbar are described below:







Button	Description
	New button. Creates a new circuit file.
	Open button. Opens an existing circuit file.
	Save button. Saves the active circuit.









Button	Description
	Cut button. Removes the selected elements and places them on the Windows clipboard.
	Copy button. Copies the selected elements and places them on the Windows clipboard.
	Paste button. Inserts the contents of the Windows clipboard at the cursor location.
	Print Circuit button. Prints the active circuit.
	Increase Zoom button. Magnifies the active circuit.
	Decrease Zoom button. Decreases the magnification of the active circuit.
	Zoom 100% button. Shows the circuit in the workspace at its normal size.
	Fit to Page button. Displays the entire active circuit in the workspace.
	Toggle Project Bar button. Switches the Project Bar on and off.
	Toggle Spreadsheet View button. Switches the Spreadsheet View on and off.
	Database Management button. Launches the Database Management dialog box.
	Create Component button. Launches the Create Component Wizard .
	Run/stop Simulation button. Starts/stops simulation of the active circuit.
	Show grapher button. Displays the grapher.
	Analyses button. Displays a list of available analyses.
	Postprocessor button. Displays the Postprocessor dialog box.

Button	Description
	Electrical Rules Checking button. Checks that the electrical rules established for the wiring of the circuit have been followed.
	Back Annotate from Ultiboard button.
	Forward Annotate button.
	In Use List . Click on the arrow to display a list of the active circuit's components.
	Help button. Launches the help file.

1.9.2.2 Component Toolbar





The buttons in the **Component** toolbar are described below. Each button will launch the place component browser (**Select a Component** dialog box) with the group specified on the button pre-selected.





Button	Description
	Source button. Selects the Source components group in the browser.
	Basic button. Selects the Basic components group in the browser.
	Diode button. Selects the Diode components group in the browser.
	Transistor button. Selects the Transistor components group in the browser.
	Analog button. Selects the Analog components group in the browser.
	TTL button. Selects the TTL components group in the browser.
	CMOS button. Selects the CMOS component group in the browser.

Button	Description
	Miscellaneous Digital button. Selects the Miscellaneous Digital component group in the browser.
	Mixed button. Selects the Mixed component group in the browser.
	Indicator button. Selects the Indicator component group in the browser.
	Miscellaneous button. Selects the Miscellaneous component group in the browser.
	RF button. Selects the RF component group in the browser.
	Electromechanical button. Selects the Electromechanical component group in the browser.
	EDAParts.com button. Launches the eda.parts.com website.
	Place Hierarchical Block button. Opens a file to be embedded as a hierarchical block.
	Place Bus button. Places a bus on the workspace.

1.9.2.3 Graphic Annotation Toolbar

The buttons in the **Graphic Annotation** toolbar are described below.









Button	Description
	Place Text button. Places a text frame on your workspace into which you can enter miscellaneous text.
	Line button. Click on this button to draw a line.
	Multiline button. Click on this button to draw a multiline.
	Rectangle button. Click on this button to draw a rectangle.











Button	Description
	Ellipse button. Click on this button to draw an ellipse.
	Arc button. Click on this button to draw an arc.
	Polygon button. Click on this button to draw a polygon.
	Picture button. Click on this button to place a picture on the workspace.

1.9.2.4 Instrument Toolbar

The buttons in the **Instruments** toolbar are described below. In each case, the button places a specific instrument on the workspace.

Some versions of Multisim do not include all of the instruments noted below.

Button	Description
	Multimeter button. Places a multimeter on the workspace.
	Function Generator button. Places a function generator on the workspace.
	Wattmeter button. Places a wattmeter on the workspace.
	Oscilloscope button. Places an oscilloscope on the workspace.
	Four Channel Oscilloscope button. Places a four-channel oscilloscope on the workspace.
	Bode Plotter button. Places a bode plotter on the workspace.
	Frequency Counter button. Places a frequency counter on the workspace.
	Word Generator button. Places a word generator on the workspace.

Button	Description
	Logic Analyzer button. Places a logic analyzer on the workspace.
	Logic Converter button. Places a logic converter on the workspace.
	IV-Analysis button. Places an IV Analyser on the workspace.
	Distortion Analyzer button. Places a distortion analyzer on the workspace.
	Spectrum Analyzer button. Places a spectrum analyzer on the workspace.
	Network Analyzer button. Places a network analyzer on the workspace.
	Agilent Function Generator button. Places an Agilent function generator on the workspace.
	Agilent Multimeter button. Places an Agilent multimeter on the workspace.
	Agilent Oscilloscope button. Places an Agilent oscilloscope on the workspace.
	Dynamic Measurement Probe button. Attaches a probe to the mouse pointer that measures voltage and frequency on any wire on your schematic. This function is only active during simulation.

1.10 Configuring Multisim 7 Preferences

You can configure most of the preferences related to schematic entry such as page size, font selection, auto-backup interval, component placement mode (either single or continuous placement.) Most configuration is done through **Options/Preferences**. Your configuration settings are saved individually with each circuit file you use, so you could have one color scheme for one circuit and another for a different circuit. You can also create default settings that affect both the current circuit and all circuits you subsequently create. For example, if you set the default workspace settings to show the component labels then when you use **File/New** to create a new circuit, that circuit will show the component labels as well. However, if your current circuit shows component labels and you simply change it to hide such labels, the change affects only your current circuit.

1.10.1 Controlling Circuit Display

You can control the way your circuit and its components appear on the screen, and the level of detail which appears.

- To set the default circuit display options for circuits, choose **Options/Preferences**. The Preferences screen appears, offering you eight tabs of options, with the Circuit tab being the active tab. Use this tab to control the colors and display details for your circuit. For other window display options, choose the desired tab. For example, to define whether grid, page bounds and titles blocks are shown, use the Workspace tab. To set the component symbols to either ANSI or DIN, use the Component Bin tab. Experiment with these options as you wish.
- To save your options for the current circuit *only*, click **OK**. To save your options as the default, affecting both the current and subsequent circuits, click **Set as Default**, then click **OK**.
- To restore your previously saved default settings (if you don't like the changes you made and would like to start over again), click **Restore Default** and then continue making changes.

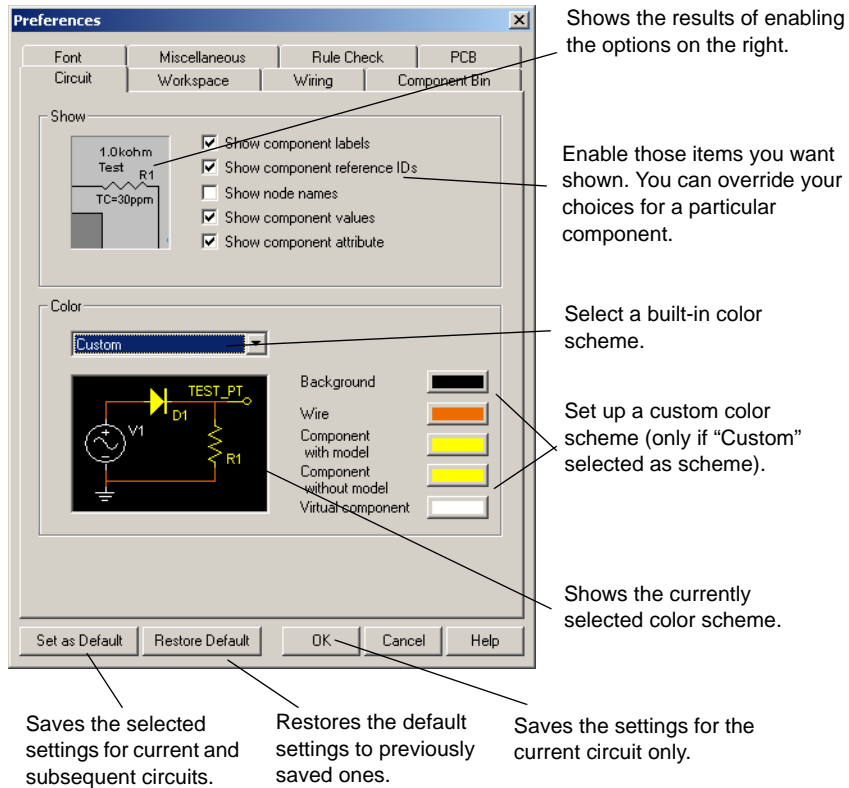

- To cancel your changes and close the screen, click **Cancel**.

1.10.2 Customizing the Interface

Options/Customize allows you to customize the menus, toolbars and keyboard shortcuts to suit your work preferences. For example, you can add a new toolbar that contains the functionality that you use frequently. It is best when you are first starting to become familiar with Multisim to use the default menus and toolbars until you become accustomed with the program. For more details, refer to the *Multisim 7 User Guide*.

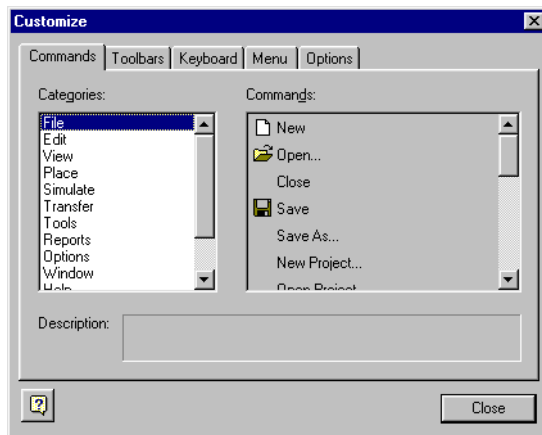

1.10.3 Other Customization Options

The **View** menu also contains some customization options that toggle on or off display of the grid, page bounds, title block, border and ruler bars. As well, the **Grapher**, the hierarchy viewer and the circuit description box can be toggled on or off.

Chapter 2

Building a Circuit

2.1 Introduction

This manual takes you through the process of building and simulating a simple circuit. The first stage is to choose the components you want to use, place them on the circuit window in the desired position and orientation, wire them together, and otherwise prepare your design.

The circuit you will build in this chapter is a simple circuit that flashes an LED on and off. When you have completed the steps in this chapter, you will have a circuit that looks like this:

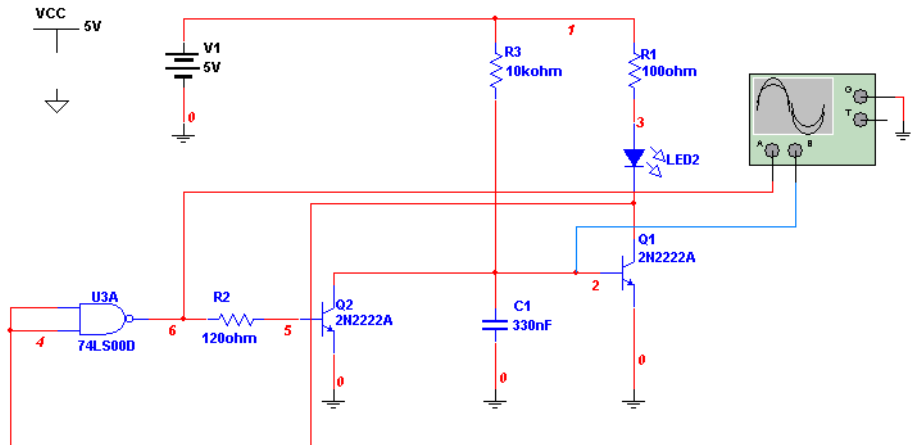

This circuit file, in its various stages of development, is shipped with Multisim. Throughout this manual you will be given detailed instructions on how to build this circuit. However, you will also find references to the files you can open to experiment with the circuit at its different stages, if you prefer.

2.2 Starting Your Circuit File

To start building your circuit file, start Multisim. Multisim automatically opens a blank circuit file with which you can work. The circuit window you see when you run Multisim has its color, size, and display options based on the previously set default settings. You can change these options to suit your needs by using the **Options/Preferences** dialog box, as described in the *Multisim 7 User Guide*.

2.3 Placing Components in the Circuit Window

You are now ready to start placing the components for your circuit. As explained in the *Multisim 7 User Guide*, Multisim offers up to three component databases (“Multisim Master” “User” and, for some Multisim editions, “Corporate Library”). For the purposes of this tutorial we are concerned only with the “Multisim Master” database, which is the component database shipped with Multisim. For more about the other databases, see the *Multisim 7 User Guide*.

2.3.1 About the Component Toolbar

By default, the component toolbar is visible as indicated below. The components you need to use to create circuits are grouped into logical divisions or groups. Each group is represented by a button on the component toolbar. Placing your cursor over one of these buttons and clicking opens the component placement browser with the selected **Group** open. Each **Group** contains a number of families of similar component types.



2.3.2 Placing Components

This section explains how to place components using the **Component** toolbar. This is the typical way of placing components. As explained in the *Multisim 7 User Guide*, you can also place components using **Place/Component**, which is useful if you are not sure which group contains the component you are interested in placing.

2.3.2.1 Placing the First Component

Step 1: Place a Battery

- To place the first component (a 5 volt battery):

1. Click on the **Source** button in the component toolbar. The **Select a Component** dialog box opens and you will see a list of the components in the selected group. Choose the **POWER_SOURCES** family and view the list of components available in that family.

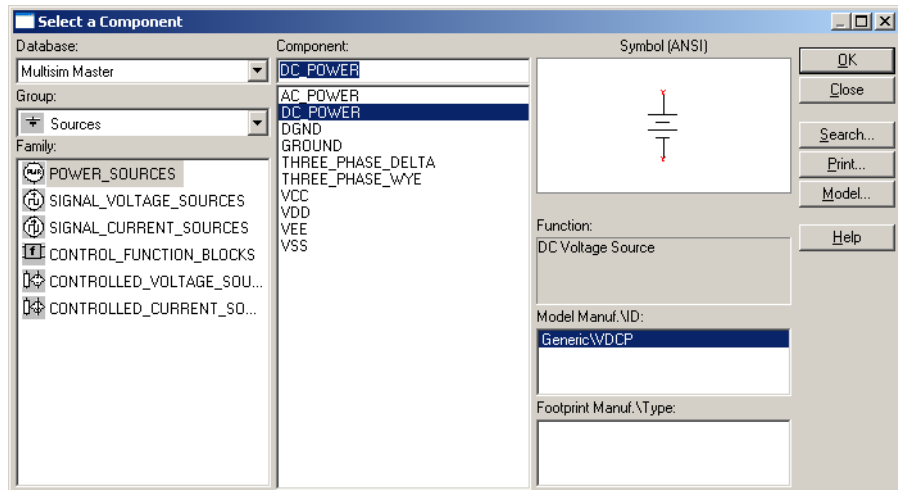

2. Choose **DC Power** from the list and click **OK**. Your cursor changes to indicate a part is ready to be placed.

A ghost image of the component appears on the circuit window showing you exactly where the component will be placed.

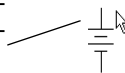

3. Move to the top left corner of the circuit window, where we want to place the battery. Click in this general area or, to be more precise, use the page borders as a guide and click in the intersection of row A and column 1. The battery appears on your circuit window: The descriptive text that appears around the various components can, if you wish, be hidden. To hide it, double-click the component. The component's properties dialog box appears with various tabs. On the Display tab, de-select the option **Use Schematic Global Setting**, then de-select the descriptive text options for the component. Show or hide descriptive text for all components by using **Options/Preferences** and changing the settings in the **Show** box of the Circuit tab.

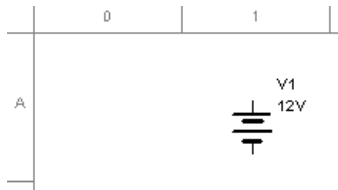

Step 2: Change the Battery's Value

By default, the battery is a 12V battery, but our circuit calls for a 5V battery. You can easily change the battery's value.

- To change the battery's value:
 1. Double-click on the battery. The battery's properties dialog box appears, with the Value tab displayed.

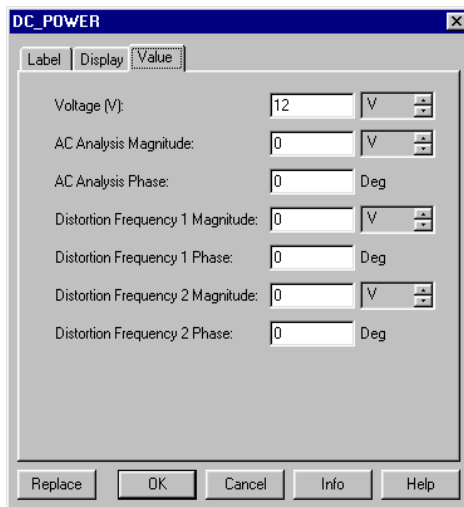

Note For more details on this dialog box and its tabs, see the *Multisim 7 User Guide*.

2. Change the “12” to a “5” and click **OK**.

This ability to change the value of a part exists only for “virtual” components. Virtual components are not real; that is, you could not buy them from a supplier. Virtual parts include all sources, virtual resistor/capacitor/inductor parts and also include other “ideal” devices intended to provide theoretical equivalents of, for example, the perfect opamp. Use virtual components to enable simulation (by providing stimuli) or to explore “what if” scenarios early in your design process.

Multisim treats virtual components slightly differently from real parts. Virtual components have a different default color from that of real components on your schematic. This is to remind you that, since they are not real, these components will not be exported to PCB layout software, should you perform this step later. You will see this difference in the next step, when you place a resistor.

2.3.2.2 Placing the Next Components

Step 1: Place a Resistor

- To place the first resistor:

1. Click on the **Basic** button in the **Component** toolbar. The **Select a Component** dialog box opens displaying a list of the components in the selected group. Choose the **Resistor** family. The **Component** list changes to display resistors available in the **Resistor** family from the “Multisim master” level of the database.
2. Scroll through the **Component** list to find the 100 ohm resistor we need for our circuit.

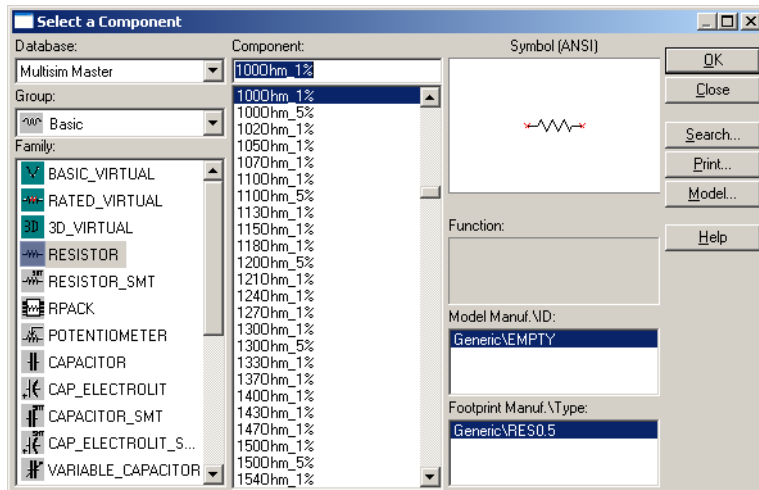

Tip To make your scroll through the **Component** list faster, simply click in the **Component** field and type the first few characters of the component’s name. For example, type “100” to move to that area of the list.

3. Select the 100 ohm resistor and click **OK** or double click on the component. The cursor will appear on the circuit window as a ghost image of the resistor.
4. Move your cursor to approximately A5 and click to place the component.

Notice that the resistor looks different from the battery you just placed—the resistor appears in a different color to remind you it is a real component (and will be exported to PCB layout software, if you choose to perform that step).

Step 2: Rotate the Resistor

To set up the resistor so it can be wired more conveniently into our circuit, we will first need to rotate it.

➤ To rotate the resistor:

1. Right-click on the resistor. A pop-up menu appears.
2. Choose **90 CounterCW** from the menu. The results look like this:



3. If you want, you can move the labels that accompany a component’s symbol. In particular, you may want to do this after some rotations, if the labels are displayed other than as you prefer. For example, you might want to move the reference ID label. Just click and drag it to the right of the symbol, or click and use the arrow keys on the keyboard to move the label in grid increments.

Step 3: Add Other Resistors

The circuit calls for two other resistors, this time a 120 ohm and a 10 kohm.

➤ To add the other resistors:

1. Following the instructions above, add a 120 ohm resistor at roughly the intersection of row D and column 2. Notice how this second resistor is given the reference ID “R2”, to indicate it is the second resistor placed.
2. Place the third resistor, a 10 kohm one, at roughly the intersection of A4 and rotate it.

Take a moment to look at the “In Use” list, just to the right of the **Standard Toolbar**. It lists all the components you have placed so far. You can easily re-use a component from this list by clicking on it.

The results should look like this:

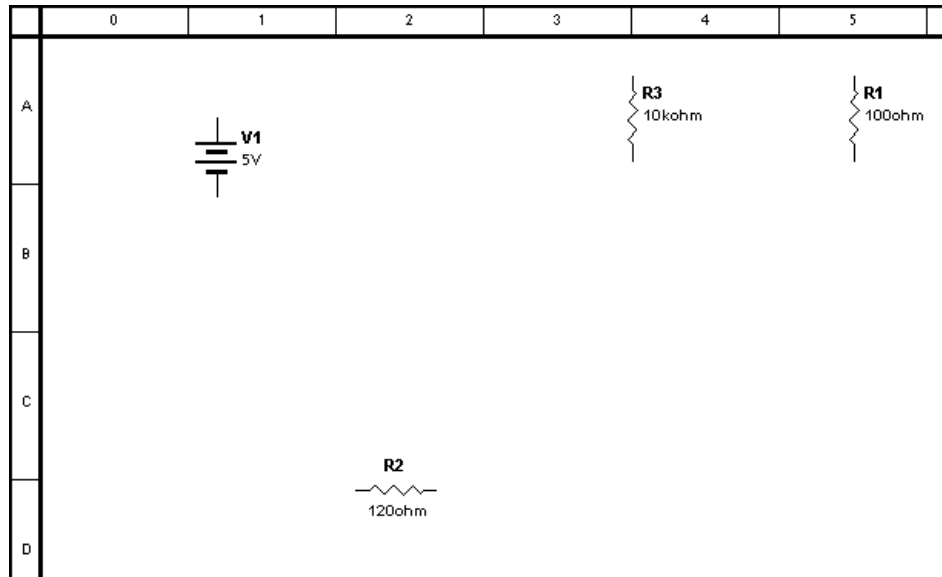

If necessary, you can easily move your placed components to the desired location. Simply click the component to select it (be sure to select the whole component, not just a label) and either drag it to the new location or use the arrow keys on your keyboard to move the component incrementally along the grid.

Step 4: Save Your Changes

- To save your changes, choose **File/Save As**, and give a name (and location) for your circuit file.

Note Do not use non-English characters (for example, those with accents) when creating folder names, file names or subcircuit names.

2.3.2.3 Placing Other Components

Following the procedures above, place the following components in the following locations:

- a red LED (from the LED Family in the Diodes Group) just below R1
- a 74LS00D (from the 74LS Family in the TTL Group), roughly at D1 (Since this component consists of four separate gates, you are prompted to choose which one you will use. All are identical, so you can choose any one.)
- a 2N2222A BJT_NPN (from the BJT-NPN Family in the Transistors Group), to the right of R2

- another 2N2222A BJT_NPN below the LED (simply copy the previous one and paste the copy at the new location)
- a 330nF capacitor (from the Capacitor Family in the Basic Group), to the right of your first BJT_NPN, and rotate it clockwise (move the labels after rotating, if desired)
- a ground (from the Power Sources Family in the Sources Group), below V1, Q1, Q2 and C1 — you may use any number of grounds in your circuit, as in this tutorial, or just one with multiple parts connected to it)
- a 5 Volt VCC (from the Power Sources Family in the Sources Group), in the top left corner of the circuit window, and a digital ground (from the Power Sources Family) just below it.

Note A circuit containing a digital component must have VCC and a digital ground placed on the circuit window. Multisim will use these two components to power the digital component. Setting the voltage of VCC is the user’s responsibility.

The results should look something like this:

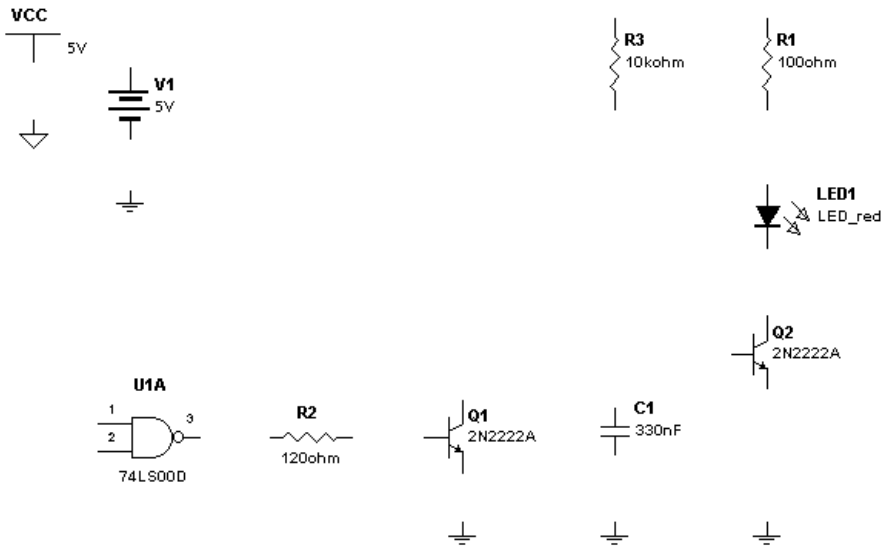

Tip To quickly move your components into line, select them and use the arrow keys on your keyboard to move the components in grid increments. Lining them up will make wiring easier.

Note Don’t forget to save your changes using **File/Save**.

2.4 Changing the Label and Color of Individual Components and Nodes

Multisim assigns labels and colors to a placed component. You can modify or move component labels, and change component colors.

- To change the label of any individual component you have placed:
 1. Double-click on the component. The component's properties dialog box appears.
 2. Click the Label tab and enter or modify the label (which must be composed of letters and numbers only—no special characters or spaces).
 3. To cancel your changes, click **Cancel**. To save your changes, click **OK**.
- To change the color of any individual component, right-click on it and choose **Color** from the pop-up menu. Choose the desired color from the dialog box that appears.

Note Changing the color of an individual component is different from changing the color scheme of the current circuit, or of the defaults set using **Options/Preferences**, as explained earlier in this manual.

2.5 Wiring

Now that you have the components placed on the circuit window, you need to wire them together. All components have pins that you use to wire them to other components. In Multisim, you can choose to wire components either automatically or manually. Automatic wiring, a feature unique to Multisim, means Multisim automatically wires the connection for you, selecting the best path between your chosen pins. Automatic wiring avoids wiring through other components or overlapping wires. Manual wiring means you control the path of the wire on the circuit window. You can even combine the two methods in a single wire, for example, starting wiring manually and letting Multisim automatically complete the wire for you.

We need to wire together the components we placed in the circuit. Automatic wiring will take care of most of our wiring needs for this circuit. To follow along with these steps, you can either continue with the circuit you've been building in this chapter, or open the file `tut1.ms7`, located in the `Tutorial` folder, to work with a circuit that has all the components appropriately placed.

2.5.1 Using Automatic Wiring

We'll begin with wiring V1 and its ground.

- To start the automatic wiring process:
 1. Click the pin coming out of the bottom of V1. The cursor changes to a cross symbol indicating that you are in wiring mode.
 2. Click the pin on the top of the ground. The wire is dragged from the first pin to wherever you move your cursor. The two components automatically become wired together and look like this:

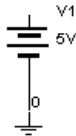

Note By default, the wires are displayed in red. To change the default, right-click on the circuit window and choose **Color** from the pop-up menu. To change the color of just a single wire, right-click on the wire and choose **Color** from the pop-up menu.

3. Using automatic wiring, make the following connections:
 - wire V1 to R1
 - wire R1 to the LED
 - wire the LED to the collector of Q2
 - wire the emitters of Q2 and Q1 to their grounds
 - wire C1 to its ground
 - wire base of Q1 to R2
 - wire R2 to pin3 (output) of U1
 - wire pin1 of U1 to pin 2 of U1
 - wire R3 to the wire running from V1 to R1 — click on the pin of R3 and then click the wire to automatically place a junction where the wires meet
 - wire base of Q2 to collector of Q1
 - wire R3 to the wire running from Q2 to Q1
 - wire C1 to the connection on the wire running from Q2 to Q1.

The results should look like this:

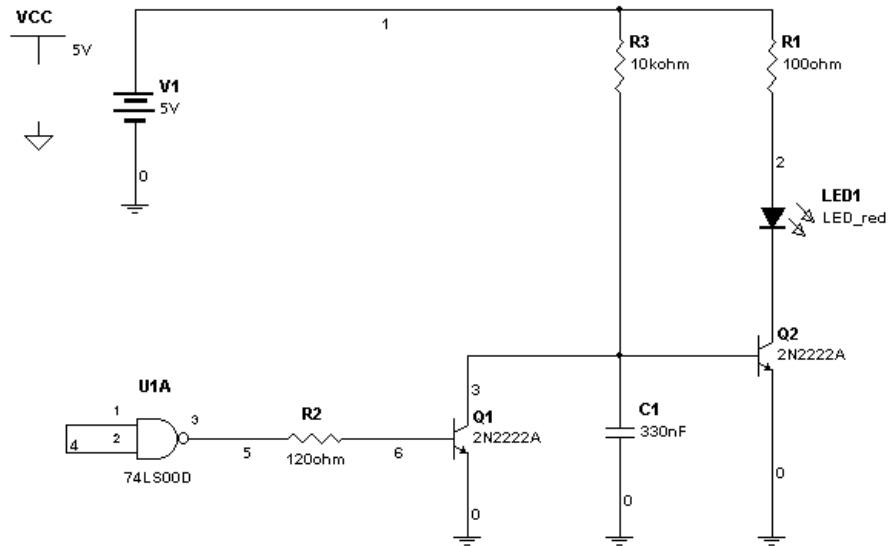

After a wire is connected between two pins the cursor returns to its normal mode and is ready for your next command.

- To delete a wire, right-click on it and choose **Delete** from the pop-up menu, or press DELETE.

2.5.2 Using Manual Wiring

We now want to connect the inputs of U1 to the wire between the LED and Q2. To have precise control over the path of the wire, we will use manual wiring. Multisim prevents you from placing two wires on a single pin. This is to prevent possible wiring errors. We therefore need to start, not from pin 1 or 2 of U1, but from the wire between them. To wire from the middle of one wire to another wire, you have to add a junction on the first wire.

- To add a junction:
 1. Choose **Place/Junction**. The junction is shown as a ghost image at the point of the cursor.
 2. Move the junction to the desired location on the wire between the inputs of U1 and click.

3. The junction appears on the wire:

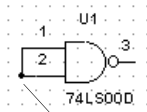

Junction

We now need to use manual wiring to ensure that the wire follows the path we want. To help position the wire appropriately, display the grid (if it is not visible).

- To display the grid, right-click on the circuit window and choose **Show Grid** from the pop-up menu.

We are now ready to wire the connection manually.

- To make a manual connection:
 1. Click the junction you just placed at the inputs of U1. Your cursor will change to a cross symbol indicating the you are in wiring mode.
 2. Drag the wire down to below the other components and click. This “fixes” the wire in its place.
 3. Drag the wire across the width of the circuit to a few grid spaces past the last component. Click again.
 4. Drag the wire up to a point across from the wire between LED1 and Q2. Click again.
 5. Drag the wire to a place on the wire between LED1 and Q2 and click again.

The results look like this:

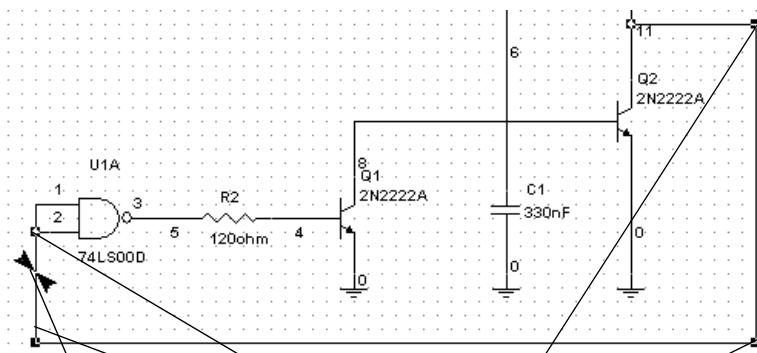

Add your own drag point by pressing the CTRL key while clicking on the wire. Modify the shape of the wire by dragging this point.

The mouse was clicked at these points. You can modify the wire by dragging these points.

Click on the wire you just made. The boxes displayed on the wire (“drag points”) show where you clicked as you placed the wire. You can modify the shape of the placed wire by clicking on any of these points and dragging the wire segment. If you want to experiment with this, save your changes first.

While the wire is selected, you can add additional drag points by using the CTRL key and clicking the wire where you want to add more points. You can also move the wire by moving your cursor over the wire and then click and drag when your cursor changes to a double arrow symbol.

Note To remove a drag point, press the CTRL key and click on the point. When you remove a drag point, the wire will stretch to a straight line between the two points on either side of the point you removed.

2.6 Using the Spreadsheet View

The Spreadsheet View allows you to get a global view of most of the properties associated with the components, nets and PCB layers in your design. If not already selected click the **Spreadsheet** button to make the spreadsheet visible. At the bottom of the workspace you will see the spreadsheet view and the three tabs that allow you to view the different properties of your design. Choose the Components tab and notice the list of components from your design. Click on the heading of a column the list will be sorted in ascending order of the column that you selected. If you click the heading again the column will be sorted in descending order.

Referenc...	Section	Family	Value/Model	Manufacturer	Footprint	Description	Label	Coordinate X/Y	Rotation	Flip	Color	VCC	VDD
XSC1								B7	Unrotated	Unflipped			
VGND		DIGITAL...		Generic				B1	Unrotated	Unflipped	■ Default		
VCC		VCC	5V	Generic		Function= T...		A1	Unrotated	Unflipped	■ Default		
V1		DC_VOLT...	5V	Generic				A2	Unrotated	Unflipped	■ Default		
U3	A	74LS	74LS00D	Texas Instrum...	DD14	Number=4...		C1	Unrotated	Unflipped	■ Default	VCC	
R3		RESISTOR	10kohm	Generic	RES1206	R=10kohm...		A5	Rotated 90	Unflipped	■ Default		
R2		RESISTOR	120ohm	Generic	RES1206	R=120ohm...		C3	Unrotated	Unflipped	■ Default		
R1		RESISTOR	100ohm	Generic	RES1206	R=100ohm...		A6	Rotated 90	Unflipped	■ Default		

2.6.1 Changing a Component's Properties Using the Spreadsheet

Click on the *Reference ID* heading to sort the list by reference designators. Scroll down the list until the resistors R1, R2 and R3 are visible. Click on R1 and then hold the shift key and click on R3. Notice how the three rows for the resistors are selected. You can change the footprint for all three items by clicking the Footprint field for any one of the resistor rows and entering the new footprint from the **Edit Footprint** dialog box. To try this yourself click on the footprint for resistor R1. Click on the **Standard Footprint** button and scroll through the list of

footprints until you find RES1206. Click **Select** and notice how all the footprints for resistors have been changed to the new value.

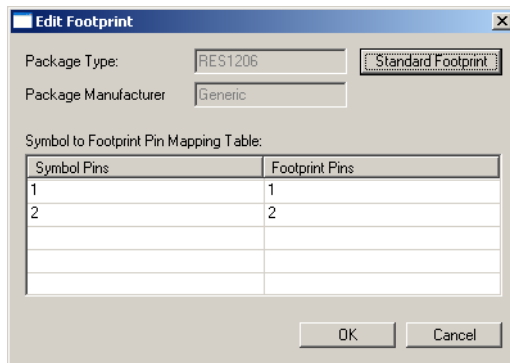

2.7 Adding a Title Block to the Circuit

Multisim allows you to add a title block your circuit from a selection of sample title blocks.

- To add a title block:
 1. Choose **Place/Title Block**.
 2. Navigate to the Titleblocks folder, select `default.tb7` and place it near the bottom right of your circuit window.
 3. Right-click on the title block and from the context menu choose **Move to Bottom Right**.
 4. To edit the title block data, choose **Options/Modify Title Block**. Enter the desired text in the fields and click **OK**.

Some versions of Multisim include the **Title Block Editor**, which allows editing of the title block layout or creation of a new layout with, for example, an embedded graphic of your company logo. Choose **Tools/Title Block Editor** to use the editor. See the *Multisim 7 User Guide* for more details.

2.8 Adding Text to the Circuit

- To add text:
 1. Choose **Place/Text**.
 2. Click on the circuit window where you want the text placed. A text box appears.
 3. Type the text—for example, type “LED Flasher”.
 4. Click anywhere on the circuit window to close the text box. The text appears in your circuit.
- To delete text, right-click on the text box and choose **Delete** from the pop-up menu or press DELETE.
- To change the color of text, right-click on the text box, choose **Color** from the pop-up menu, and choose the desired color.
- To edit text, double-click on the text box and make your changes. Click any location out of the text box to stop editing text.
- To move text, click on the text box and drag it to a new location.

2.9 Adding Graphic Annotation to the Circuit

The following example places a rectangle on the workspace.

- To add graphic annotation:
 1. Choose **Place/Graphics/Rectangle**.
 2. Click and hold the mouse button on the circuit window where you want the upper left corner of the rectangle placed.
 3. While still holding the mouse button drag a rectangle by rolling the mouse down and to the right. When you let go of the mouse button the rectangle will be drawn on the circuit.
- To delete the rectangle, click on the rectangle and choose **Delete** from the pop-up menu or press DELETE.
- To change the color of the rectangle, right-click on the rectangle, choose **Pen Color** from the pop-up menu, and choose the desired color.
- To change the fill color of the rectangle, right-click on the rectangle, choose **Fill Color** from the pop-up menu, and choose the desired color.
- To move the rectangle, click on the rectangle and drag it to a new location.

2.10 Conclusion

You have now experimented with the different ways of locating, placing and wiring components on the circuit window. You have also seen some of the options available to you for controlling the appearance of your circuit. Before we go on to add an instrument, we will explore editing components in the next chapter.

Chapter 3

Editing a Component

This chapter gives you a brief introduction to the kinds of modifications you can make by using component editing and the in-place editor. It shows you how to select the type of modification you wish to make and the component you wish to modify.

Because there are several different types of modifications you can make, an explanation of specific tasks is beyond the scope of this manual. For details on editing components, refer to the *Multisim 7 User Guide*.

3.1 Introduction to Component Editing

Component editing allows you to modify any component stored in Multisim's component database. For example, an existing component might now be available in a new package (originally pin-through hole, now surface mount). You can easily copy the component information and change only the package details to create this new component. You can also use component editing to create your own component (and place it into the database), or delete a component from the database. In the component database each component is identified by seven types of information, each accessed through a separate tab:

- general information (such as component name, manufacturer, function, date the component was created and the author of the component).
- symbol (pictorial representation of the component for schematic capture).
- model (information used to represent the actual operation/behavior of the component during simulation) — necessary only for a component that will be simulated.
- pin model (model information for simulating the interface to the component)
- footprint (the package information that Multisim uses when exporting a schematic diagram containing this component to a PCB layout package such as Ultiboard, also from Electronics Workbench).
- Electrical Parameters of the components.
- User Fields (if used to further define the components. The field titles can be modified by using **Tools/Database Management**.)

Parts can also be created using the **Component Wizard**. For details, refer to the *Multisim 7 User Guide*.

3.2 Editing a Component

1. Choose **Tools/Database Management** from the **Standard** toolbar.
2. Choose the **Component** tab and select the component to edit from the component list.

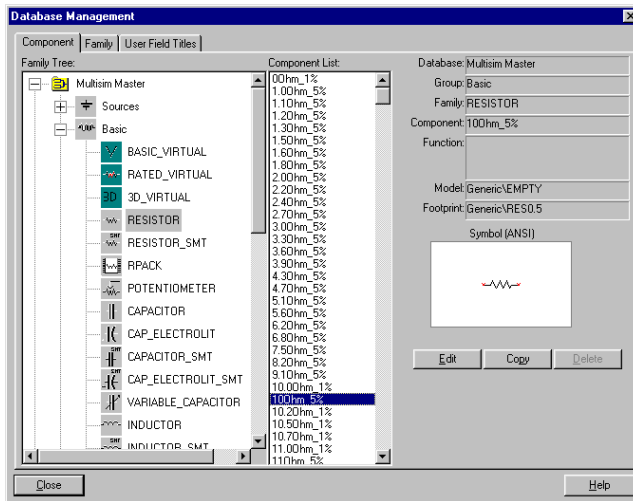

3. Click **Edit**.
4. The **Component Properties** dialog box opens. Choose the **Symbol** tab and click **Edit**.
5. The **Symbol Editor** will start with a copy of the component's symbol for you to edit. To actually modify a symbol, a model, or a footprint, is somewhat involved and is therefore beyond the scope of this manual. For now choose **File/Exit** to close the **Symbol Editor**.
6. Click the **Cancel** button to close the **Component Properties** dialog box and return to Multisim. For more information about using these tabs, see the *Multisim 7 User Guide*.

3.3 Editing a Symbol Using In-Place Edit

You may want to edit the symbol for a component on a circuit to change the position of a pin or add some descriptive text.

➤ To use the **In-Place Symbol Editor**:

1. Select the component you wish to edit.
2. Right-click on the component to activate the context menu.
3. Choose **Edit Symbol** to start the **In-Place Symbol Editor**. You can move pins and add descriptive text or graphics to the symbol.

Note The **In-Place Symbol Editor** does not allow you add pins as this would require a change in the model also. For detailed instructions on how to change a model or other properties of a component see the *Multisim 7 User Guide*.

3.4 Conclusion

In this chapter you have been introduced to component editing and using the **In-Place Symbol Editor**.

Chapter 4

Adding Instruments to Your Circuit

This chapter gives you a brief overview of Multisim’s instrument functions and takes you through the steps of adding an instrument to your circuit. Multisim offers a variety of virtual instruments. This chapter describes the oscilloscope—for other instruments, please see the *Multisim 7 User Guide*.

4.1 Introduction

Multisim provides a number of virtual instruments. You use these instruments to measure the behavior of your circuits. These instruments are set, used and read just like their real-world equivalents. They look and feel just like the instruments you’ve seen and used in a lab. Virtual instruments are one of the best and easiest ways of examining your circuit’s behavior by displaying the results of simulation.

The instrument toolbar is displayed by default. If your instrument toolbar is not displayed, click the **View/Toolbars/Instrument Toolbar** menu item. When you select this menu item, the **Instruments** toolbar appears. It contains one button for each instrument.

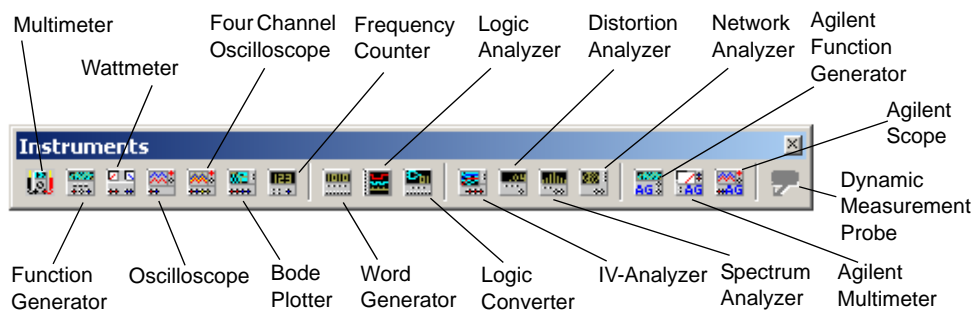

Virtual instruments have two views:

1. The instrument icon which appears when you select the instrument from the toolbar and place it on the workspace and attach to your circuit.

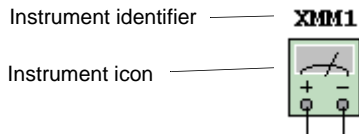

2. The opened instrument, where you set the instrument's controls and display options.

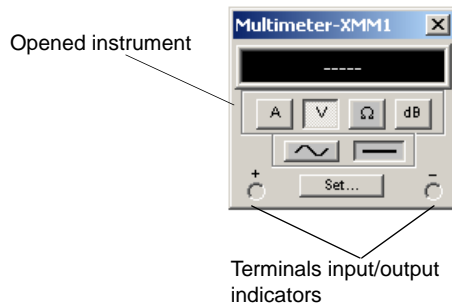

4.2 Adding and Connecting Instruments

For the purposes of this tutorial, we want to add an oscilloscope to the circuit. Either carry on with the circuit you have been creating so far, or open the file `tut2.ms7` (which has been properly wired) from the `Tutorial` folder and proceed.

Step 1: Add an oscilloscope

- To add the oscilloscope:



1. Click the **Oscilloscope** button in the **Instruments** toolbar and move your cursor to the circuit window. Your cursor will appear as the ghost image of the instrument.
2. Move the cursor to the right side of your circuit and click.
3. The oscilloscope icon appears on the circuit window.
4. You now need to wire the oscilloscope into your circuit.

Step 2: Wire the oscilloscope to the circuit

- To wire the oscilloscope into your circuit:
 1. Click the A terminal on the oscilloscope icon and drag a wire to the junction between the output of U1 and R2.
 2. Click the B terminal on the oscilloscope icon and drag a wire to between Q2 and C1.

Your circuit should look like this:

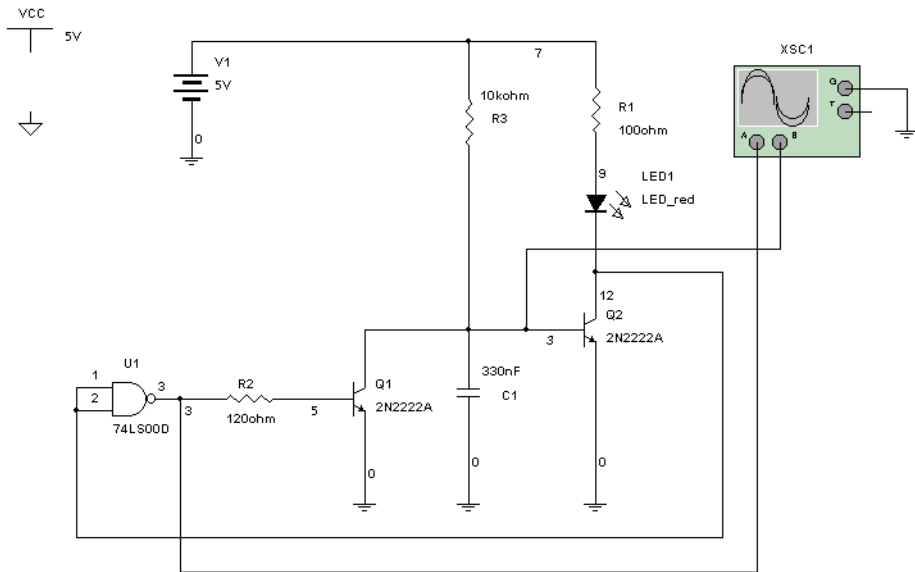

My tutorial circuit

You'll see the results of your work in the next chapter when you simulate the circuit.

4.3 Configuring Instrument Settings

Each virtual instrument provided by Multisim includes its own series of optional settings that control its display.

- To open the oscilloscope, double-click the oscilloscope icon. The oscilloscope looks like this:

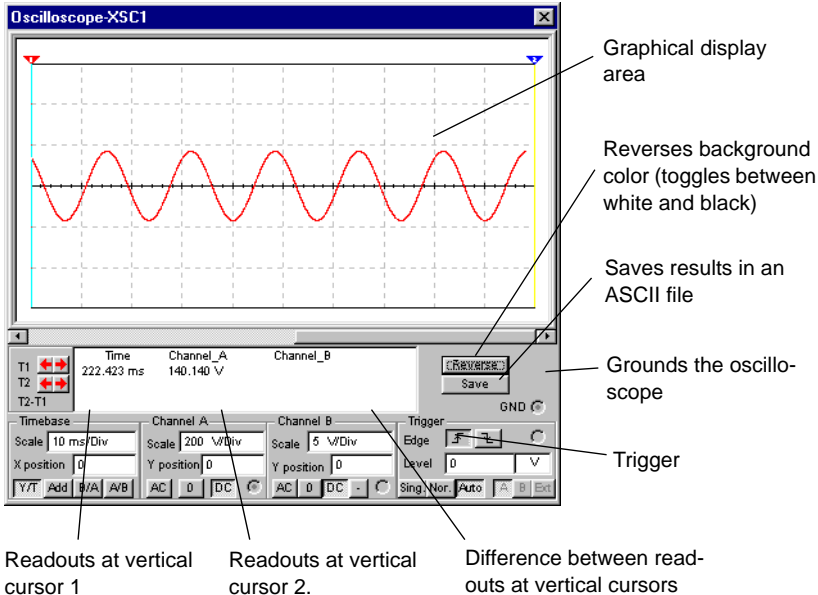

The time base section of the scope's panel controls the scale of the oscilloscope's horizontal or x-axis when comparing magnitude against time (Y/T)

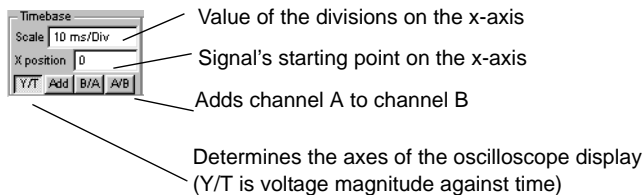

To get a more readable display, adjust the timebase in inverse proportion to the frequency—the higher the frequency, the lower (or more magnified) the time base.

- To set the time base for our circuit:
- Set the timebase scale (which should use the waveform magnitude against time (Y/T) axes) to $20 \mu\text{s}/\text{Div}$ to best display the frequencies in our circuit.
 - Set the Channel A scale to $5\text{V}/\text{Div}$, and click **DC**.
 - Set the Channel B scale to $500 \text{mV}/\text{Div}$, and click **DC**.

The results should look like this:

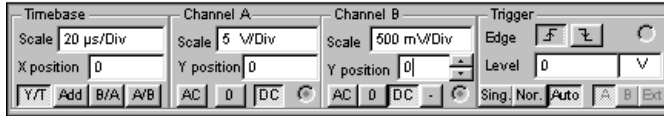

4.4 Conclusion

Now that an instrument is in place and configured correctly for the circuit, you can simulate and see the results displayed on the oscilloscope, as explained in the following chapter.

Chapter 5

Simulating Your Circuit

This chapter explains how to carry out a simulation on your circuit and see the results displayed on the oscilloscope.

5.1 Simulating your Circuit

You are now ready to simulate your circuit.

You can either continue with the circuit you've been building in this chapter, or open the files `tut3.ms7` from the `Tutorial` folder to begin with all the components correctly placed and wired together, and with the oscilloscope wired and set up correctly.



- To simulate the circuit, click the **Simulate** button.

5.2 Viewing Simulation Results

The simulation begins when the **Simulate** button is clicked, but we need some way of displaying the results. One of the best ways is to use the oscilloscope we added earlier.

- To see the results in the oscilloscope, if necessary, double-click the oscilloscope icon to “open” the instrument display, if it isn't already open.

If you changed the instrument settings as described in the previous chapter, you should soon see results looking something like this:

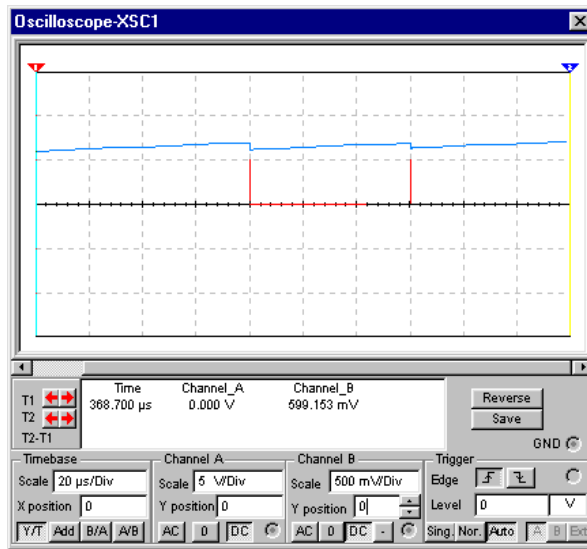

Also note that on the circuit window, in a capability unique to Multisim, the LED flashes on and off, displaying its behavior as it responds to circuit source stimulation during simulation.

We will now halt simulation of our circuit.

- To stop the simulation, click the **Simulate** button which toggles the simulation off.

5.3 Using the Dynamic Measurement Probe

When the simulation is running the Dynamic Measurement Probe allows you to obtain instantaneous measurements at various points throughout the circuit.

- To use the Dynamic Measurement Probe:
 1. Start the simulation by clicking on the **Simulate** button.
 2. From the instrument toolbar select the dynamic measurement probe and notice a small window opens. When you place the probe over a wire in the circuit you will see the voltage and frequency values at that point. Move the probe to other wires in the circuit to obtain other readings.

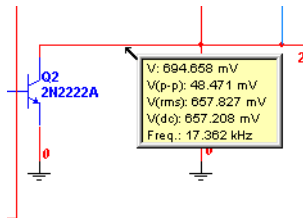

- To stop the simulation, click the **Simulate** button which toggles the simulation off.

5.4 Conclusion

You have learned how to begin simulation and display the simulation results on an instrument. In the next chapter you will see how to perform an analysis on your circuit and see the results of that analysis.

Chapter 6

Performing Analyses on Your Circuit

This chapter outlines basic information on using Multisim 7 analyses and explains how to perform one such analysis on your circuit.

6.1 The Analyses

Multisim provides you with many different types of analyses. Each one includes step-by-step instructions, provided on-line, to guide you through its use.

When you perform an analysis, the results are displayed on a plot in the Multisim Grapher (unless you specify otherwise) and saved for use in the Postprocessor.



- To choose an analysis click the **Analysis** button in the **Standard** toolbar and select an analysis from the menu that appears. When you select an analysis you will see a dialog box with several tabs which for most analyses including:
- the Analysis Parameters tab, where you set the parameters for this particular analysis
 - the Output Variables tab, where you specify which nodes are to be analyzed and what is to be done with the results
 - the Miscellaneous Options tab, where, if you wish, you can choose a title for the plot, as well as other options
 - the Summary tab, where, if you wish, you can see a consolidated view of all the settings for the analysis.

For complete information on using the analyses dialog boxes, refer to the *Multisim 7 User Guide*.

6.2 About Transient Analysis

In the *Multisim 7 User Guide*, each analysis is described in detail, including the theory behind what Multisim does to perform the analysis. It is not necessary that you understand this information, which is provided primarily for the sake of completeness.

In transient analysis, also called time-domain transient analysis, Multisim computes the circuit's response as a function of time. Each input cycle is divided into intervals, and a DC analysis is performed for each time point in the cycle. The solution for the voltage waveform at a node is determined by the value of that voltage at each time point over one complete cycle.

6.3 Running the Analysis

➤ To initiate the analysis:



1. Click the **Analysis** button on the **Standard** toolbar and choose **Transient Analysis** from the menu. The simplified **Transient Analysis** dialog box appears, offering four tabs. To view the full dialog box with all the options and information displayed, as in the example shown below, click **More**.

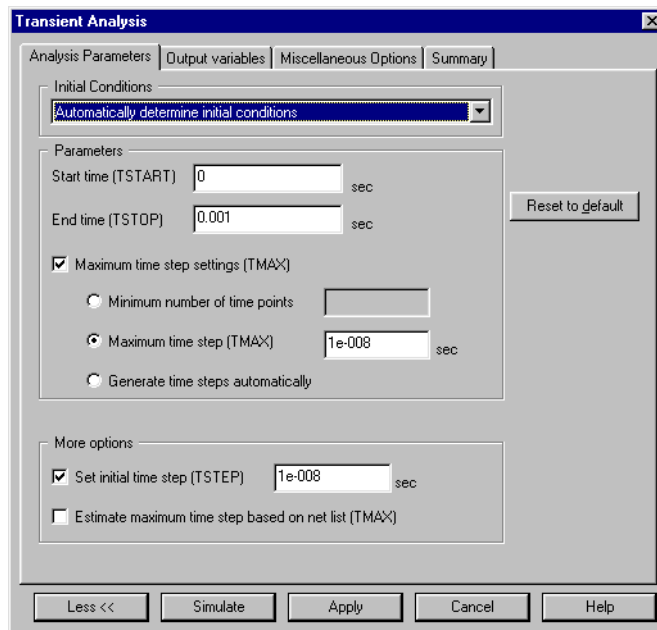

The Miscellaneous tab offers options that provide you with additional flexibility, but that are not required. Use this tab to set a title for the analysis results, to check if the circuit is valid for analysis and to set custom analysis options.

The Summary tab offers a quick overview of all the various settings for your analysis. It is not required, but you can use it to view summary information about your analysis once it is complete.

To perform the analysis, you have to set values on the other two tabs.

Step 1: Choose Output Variables

We are going to want to perform the Transient Analysis on nodes 2 (between Q1 and Q2) and 6 (from pin 3 of the gate). Choose those nodes from the available nodes on the Output Variables tab.

Note If you are still using your circuit, your node numbers may not match the ones above (node 2 and 6). This is likely a result of your circuit being wired correctly, but in a different sequence from the steps we suggested for the tutorial circuit. You can choose to continue to use your circuit and select the appropriate node numbers for the equivalent place in your circuit, or load `tut3.ms7` from the `Tutorial` folder.

- To select the nodes:
 1. Select 2 from the **Variables in circuit** list and click **Add**.
 2. Select 6 from the **Variables in circuit** list and click **Add**.

The results look like this (if your dialog box doesn't look like this, click **More**):

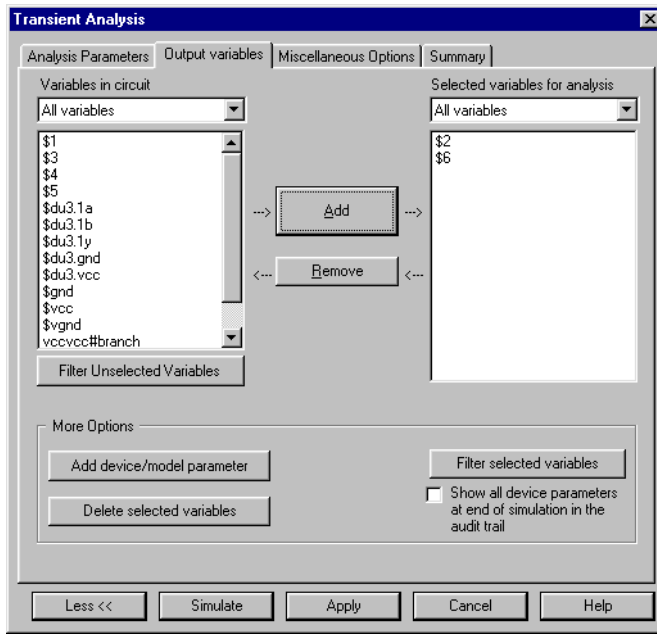

Step 2: Set the Analysis Parameters

Analysis parameters are set on the first tab as shown earlier in the chapter, and for our circuit can remain at their default values. Typically however, you would set the parameters in the Analysis Parameters tab (they are different for each type of analysis) based upon the circuit and simulation you are performing. Refer to the *Multisim 7 User Guide* for more details.

Step 3: View the Results

- To see the results, click **Simulate**. You see the following display:

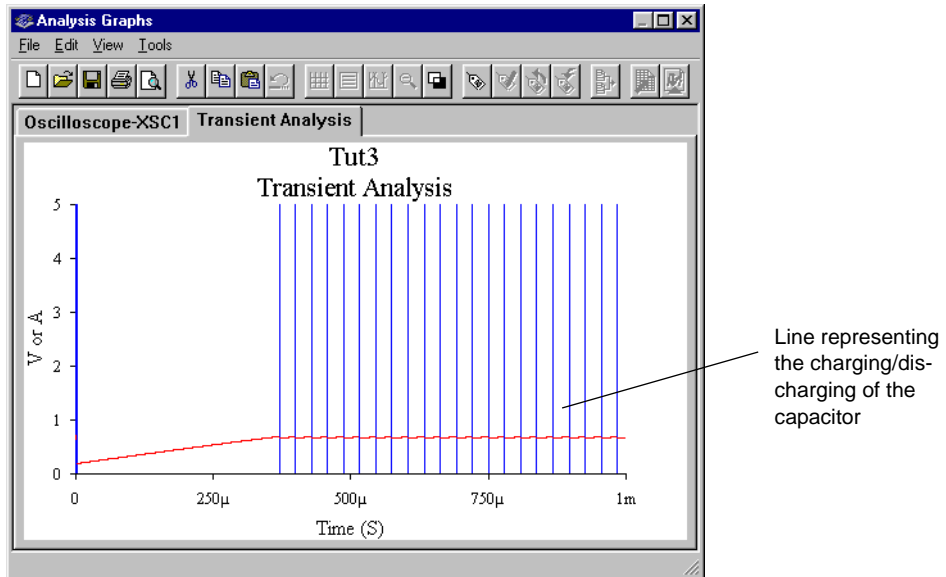

The results show how the capacitor (the blue line) charges as a result of the spikes in the red lines.



- To see a key to the line color, click the legends button.

Note The Grapher window shows two tabs—one for the analysis you just ran, and one for the results of the simulation you ran in the previous chapter and viewed using the oscilloscope.

The Multisim Grapher offers a variety of tools for examining the results of your simulation and analysis. Take some time to experiment with the different buttons and commands. For example, in the Transient Analysis tab, by dragging the cursor, you create a “zoom” box. See the *Multisim 7 User Guide* for full details.

6.4 Conclusion

This chapter introduced you to the primary steps in performing an analysis in Multisim.

Chapter 7

Generating a Report

This chapter explains how to create a Bill of Materials (BOM).

7.1 Introduction

Multisim allows you to generate a number of reports: Bill of Materials (BOM), Component Detail Report, Netlist Report, Schematic Statistics, Spare Gates and the Cross Reference Report. This chapter uses the BOM as an example. The other reports are explained in the *Multisim 7 User Guide*.

7.2 Creating and Printing a BOM



A bill of materials lists the components used in your design and therefore provides a summary of the components needed to manufacture the circuit board. Information provided in the Bill of Materials includes:

- quantity of each component needed
- description, including the type of part (example: resistor) and value (examples: 5.1 Kohm)
- reference ID of each component
- package or footprint of each component
- in the Power Professional edition of Multisim all user fields and their values where the data has been entered are available. For example, price, availability and supplier can be reported for each component that has such fields. For more on user fields, see the *Multisim 7 User Guide*.



- To create a BOM for your circuit:
 1. Click the **Reports** menu and choose **Bill of Materials** from the menu that appears.
 2. The report appears, looking similar to this:

Quantity	Description	Reference_ID	Package
1	LED, LED_red	LED2	Generic\LED1
2	74LS, 74LS00D	U3	Generic\DD14
3	RESISTOR, 100ohm	R1	Generic\RES1206
4	RESISTOR, 10kohm	R3	Generic\RES1206
5	CAPACITOR, 330nF	C1	\cap4
6	BJT_NPN, 2N2222A	Q1, Q2	\TO-18
7	RESISTOR, 120ohm	R2	Generic\RES1206

-  ➤ To print the **Bill of Materials**, click the **Print** button. A standard Windows print screen appears, allowing you to choose the printer, number of copies, and so on.
-  ➤ To save the **Bill of Materials** to a file, click the **Save** button. A standard Windows file save dialog box appears, allowing you to specify the path and file name.

Because the **Bill of Materials** is primarily intended to assist in procurement and manufacturing, it includes only “real” parts. That is, it excludes parts that are not real or able to be purchased, such as sources or virtual components.
-  ➤ To see a list of components in your circuit that are not “real” components, click the **Virtual** button. A separate window appears, showing these components only.

7.3 Conclusion

Multisim provides a number of report generation capabilities, including the BOM described in this chapter.

You have now been through the basic steps in creating and simulating a circuit. The other buttons on the **Standard** toolbar include **Electrical Rules Check (ERC)**, **Forward** and **Backward Annotation**. These items are discussed in the *Multisim 7 User Guide*.