

# CONCURRENT MAJOR IN BIOMEDICAL ENGINEERING & MECHANICAL ENGINEERING (9 SEMESTERS – 148 credits)

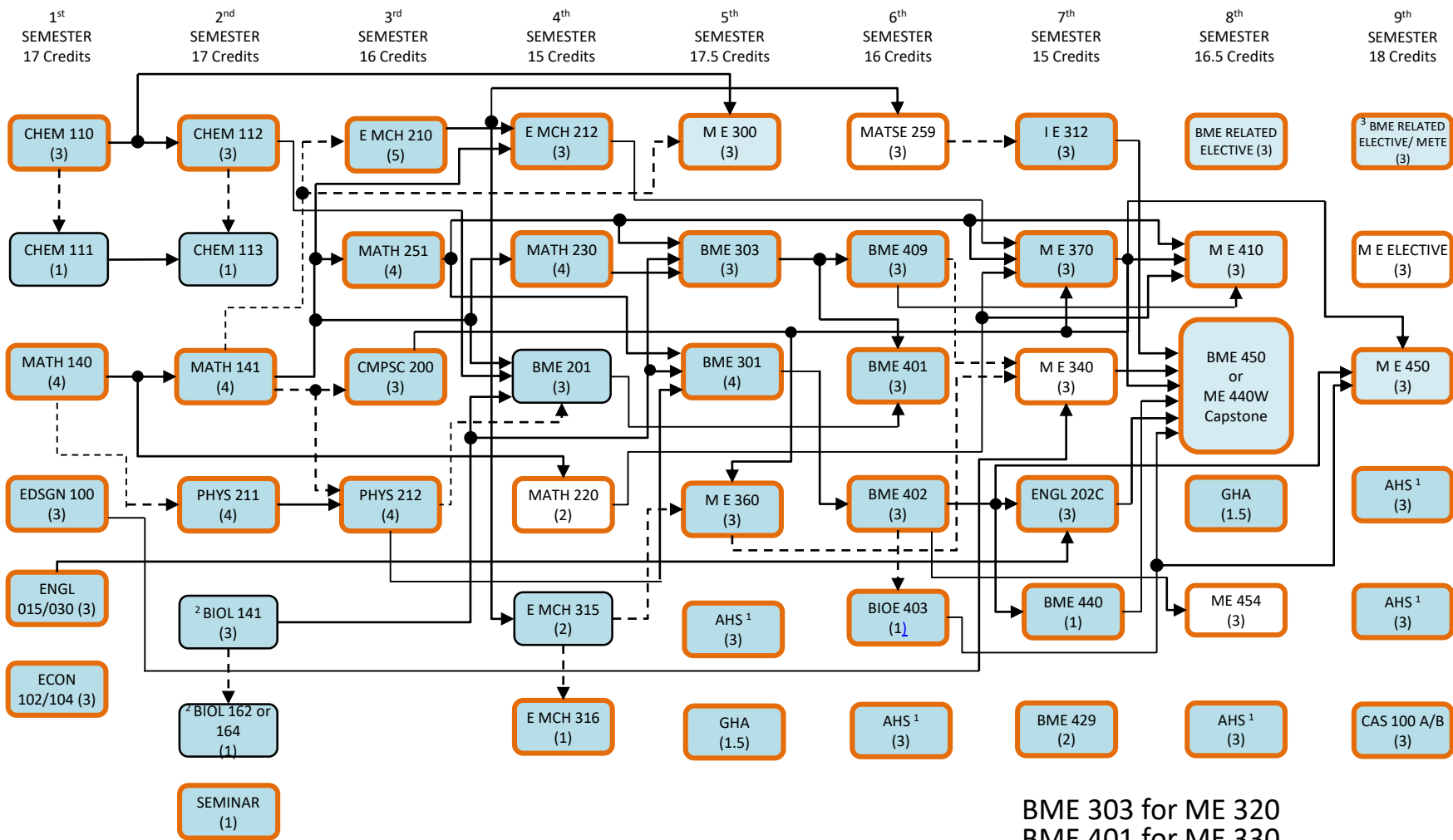

<sup>1</sup> US Cultures and IL Cultures and integrative studies requirements are satisfied in conjunction with AHS courses.

<sup>2</sup> BIOL240W can be taken as an alternate option to BIOL 141 & 162 or 164

<sup>3</sup> 3 credits BME Related Elective also needs to meet ME-ETE requirements

ME degree requirement

BME degree requirement

BME 303 for ME 320  
BME 401 for ME 330  
BME 402/403 for ME 348  
BME 440 for ME 390/490  
BME 429 for ME lab

→ = Prerequisite      - - - - - → = Prerequisite or Concurrent